

INSTRUCTION MANUAL

REFRACTORS/REFLECTORS WITH ALT-AZIMUTH MOUNT

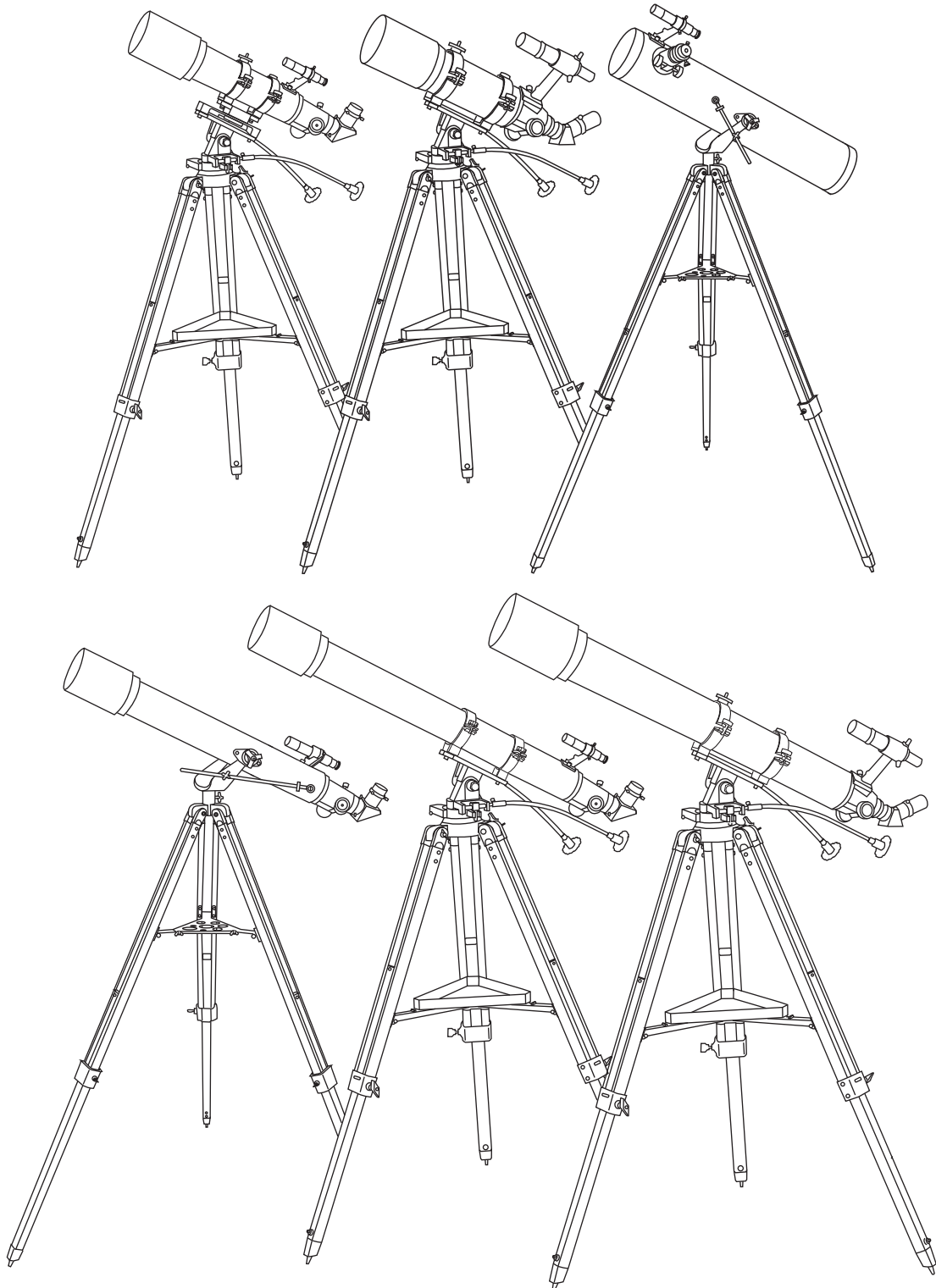

AZ1 & AZ2 MOUNTS

Refractor/AZ2

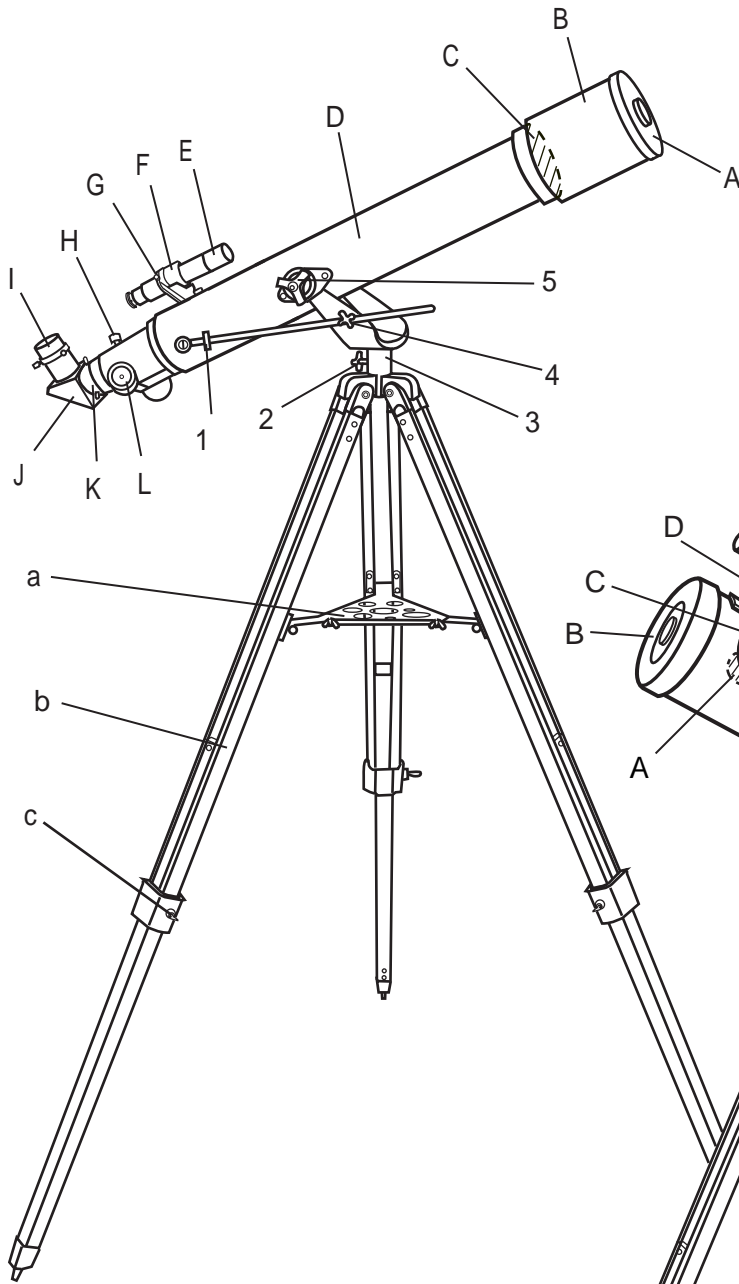

AZ2	
A.	Dust Cap / Mask (Remove before Viewing)
B.	Dew Cap / Sun Shade
C.	Objective Lens
D.	Telescope Main Tube
E.	Finderscope
F.	Finderscope Bracket
G.	Alignment Screws
H.	Focus Locking Screw
I.	Eyepiece
J.	Diagonal
K.	Focus Tube
L.	Focus Knob
1.	Altitude fine-adjustment control
2.	Azimuth Lock
3.	Yoke Mount
4.	Altitude Lock Knob
5.	Yoke Locking Knob
a.	Accessory Tray
b.	Tripod Leg
c.	Height Adjustment Clamp

Refractor/AZ1

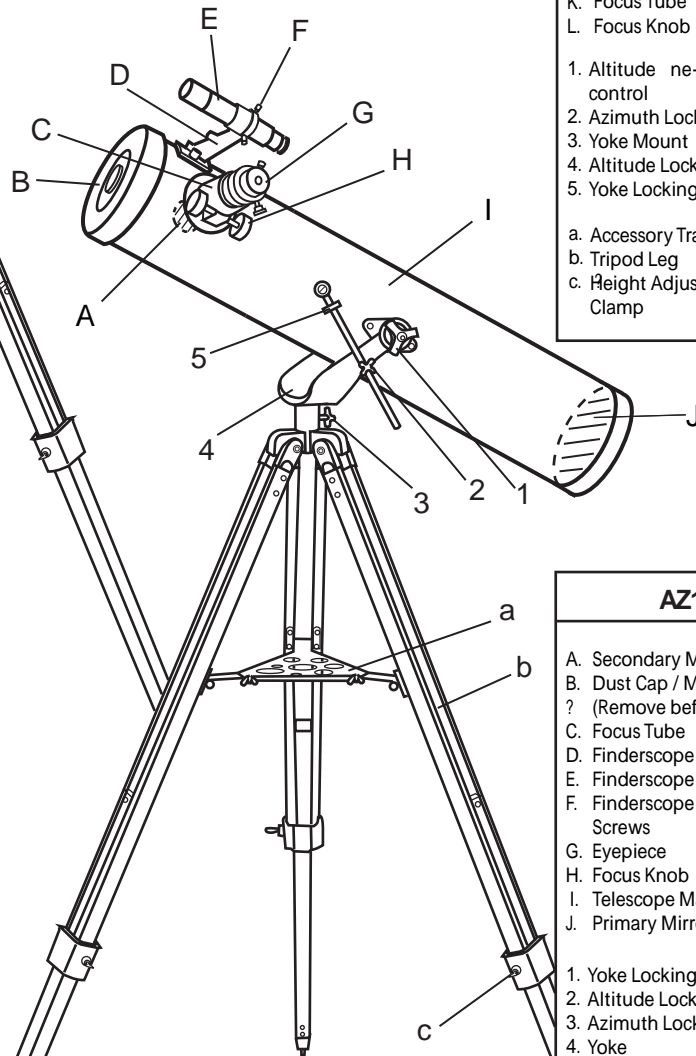

AZ1	
A.	Secondary Mirror Position
B.	Dust Cap / Mask (Remove before Viewing)
C.	Focus Tube
D.	Finderscope Bracket
E.	Finderscope
F.	Finderscope Adjustment Screws
G.	Eyepiece
H.	Focus Knob
I.	Telescope Main Tube
J.	Primary Mirror Position
1.	Yoke Locking Knob
2.	Altitude Lock Knob
3.	Azimuth Lock Knob
4.	Yoke
5.	Altitude Fine Adjustment Control
a.	Accessory Tray
b.	Tripod Leg
c.	Height Adjustment Clamp

AZ3 MOUNTS

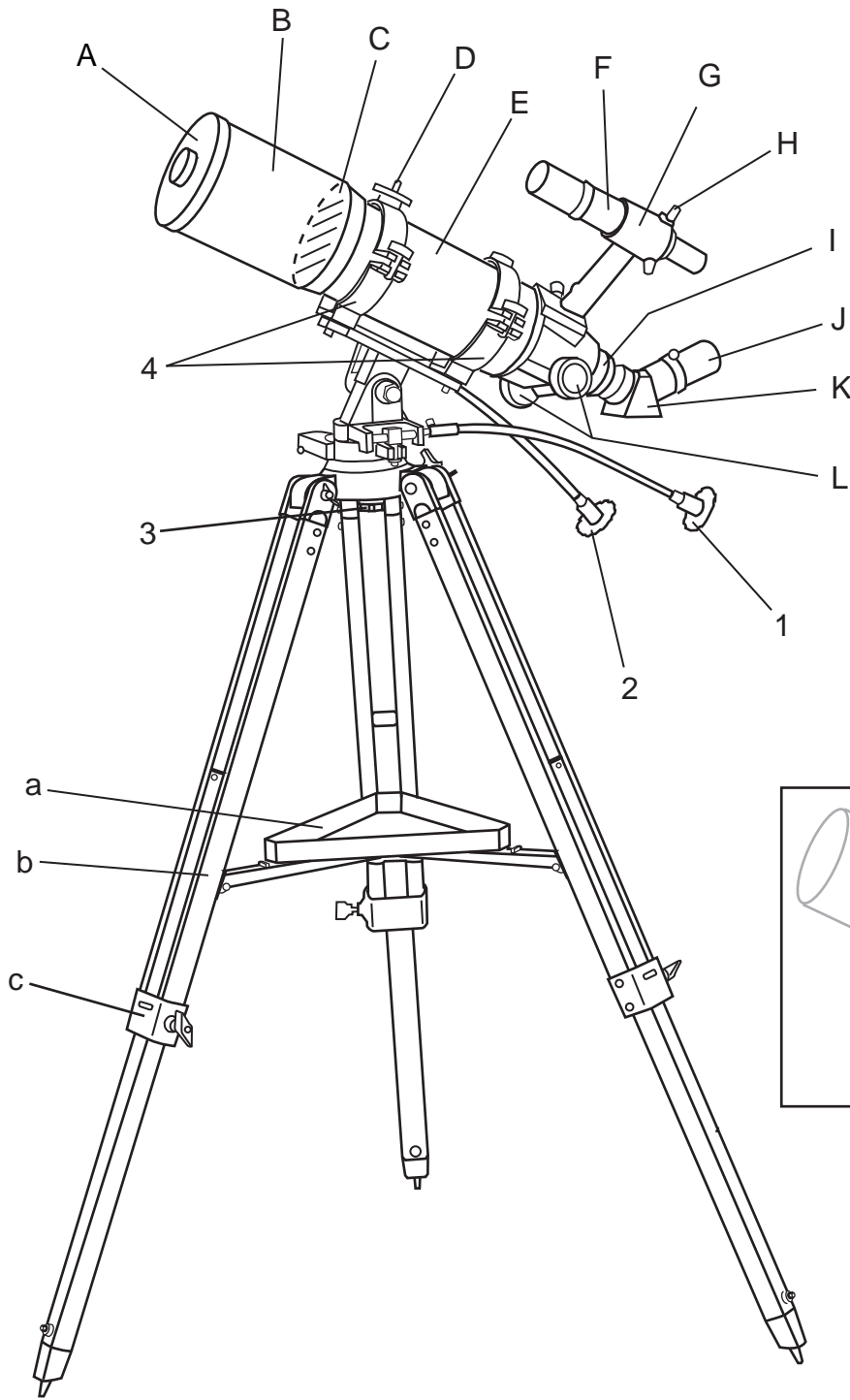

AZ3	
A.	Dust Cap / Mask (Remove before Viewing)
B.	Dew Cap / Sun Shade
C.	Objective Lens
D.	Piggyback Bracket
E.	Telescope Main Body
F.	Finderscope
G.	Finderscope Bracket
H.	Alignment Screws
I.	Focus Tube
J.	Eyepiece
K.	Diagonal
L.	Focus Knob
1.	Azimuth Flexible Control Cable
2.	Altitude Flexible Control Cable
3.	Azimuth Adjustment Knob/ 4.
4.	Tube Rings
a.	Accessory Tray
b.	Tripod Leg
c.	Height Adjustment Clamp

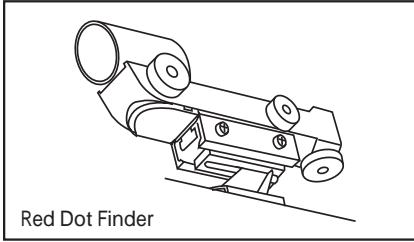
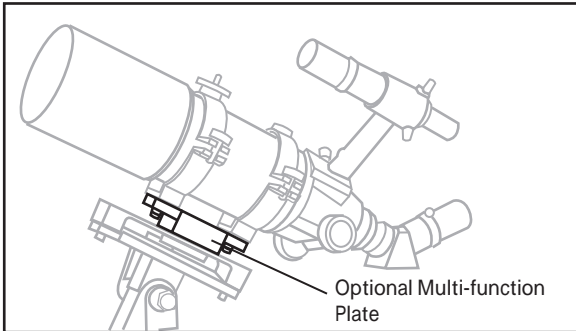

TABLE OF CONTENTS

Assembling Your Telescope	5
For AZ1 & AZ2	
Tripod Set up	5
Telescope Assembly	5
Finderscope Assembly	6
Eyepiece Assembly	6
For AZ3	
Tripod Set up	7
Telescope Assembly	7
Finderscope/Red Dot Finder Assembly	8
Eyepiece Assembly	8
Operating Your Telescope	9
Aligning the Finderscope	9
Using the Red Dot Finder	9
Operating the AZ1/AZ2 Mount	10
Operating the AZ3 Mount	10
Using the Barlow Lens	10
Focusing	10
Using the Camera Adapter Tube	11
Pointing Your Telescope	11
Calculating the Magnification (power)	12
Calculating the Field of View	12
Calculating the Exit Pupil	12
Observing the Sky	13
Sky Conditions	13
Selecting an Observing Site	13
Choosing the Best Time to Observe	13
Cooling the Telescope	13
Adapting Your Eyes	13
Proper Care for Your Telescope	14
Collimating a Newtonian	14
Cleaning Your Telescope	15

Before you begin

This instruction manual is applicable to all the models listed on the cover. Take a moment to find the model closest to your telescope on p.2 and p.3. Follow the instructions for your specific model in the manual. Read the entire instructions carefully before beginning. Your telescope should be assembled during daylight hours. Choose a large, open area to work to allow room for all parts to be unpacked.

Caution!

NEVER USE YOUR TELESCOPE TO LOOK DIRECTLY AT THE SUN. PERMANENT EYE DAMAGE WILL RESULT. USE A PROPER SOLAR FILTER FOR VIEWING THE SUN. WHEN OBSERVING THE SUN, PLACE A DUST CAP OVER YOUR FINDERSCOPE TO PROTECT IT FROM EXPOSURE. NEVER USE AN EYEPIECE-TYPE SOLAR FILTER AND NEVER USE YOUR TELESCOPE TO PROJECT SUNLIGHT ONTO ANOTHER SURFACE, THE INTERNAL HEAT BUILD-UP WILL DAMAGE THE TELESCOPE OPTICAL ELEMENTS.

TRIPOD SET UP

Fig.1

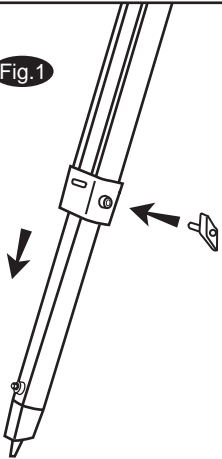

ADJUSTING TRIPOD LEGS (Fig.1)

- 1) Slowly loosen the height adjustment clamp and gently pull out the lower section of each tripod leg. Tighten the clamps to hold the legs in place.
- 2) Spread the tripod legs apart to stand the tripod upright.
- 3) Adjust the height of each tripod leg until the tripod head is properly leveled. Note that the tripod legs may not be at same length when the equatorial mount is level.

Fig.2

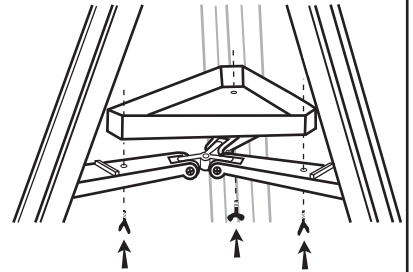

ATTACHING THE ACCESSORY TRAY (Fig. 2)

- 1) Place the accessory tray on top of the bracket, and secure with the locking knob from underneath.

TELESCOPE ASSEMBLY

AZ1 (reflector)

AZ2 (refractor)

Fig.3

Fig.3

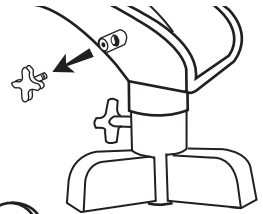
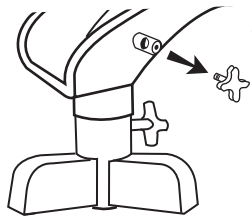
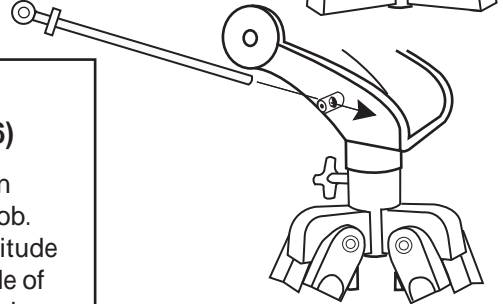
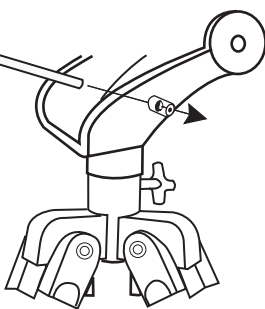

Fig.4

Fig.4



ATTACHING TELESCOPE MAIN TUBE TO MOUNT (Fig. 3, 4, 5, 6)

- 1) Unscrew the machine screw on the altitude control locking knob.
- 2) Insert the micro-adjustable altitude control into the hole on the side of the altitude control locking knob.
- 3) Slide telescope tube into slots on end of yoke mount. Secure telescope tube onto yoke mount using the yoke locking knobs without overtightening.
- 4) Remove machine screw from telescope tube and use this to fasten the micro-adjustable altitude control.

Fig.5

Fig.5

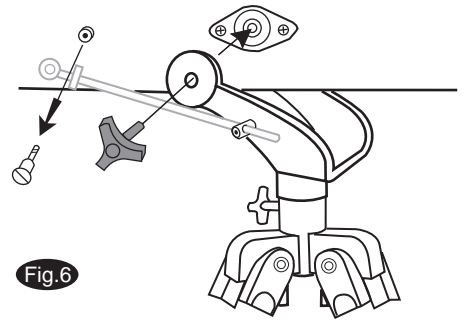
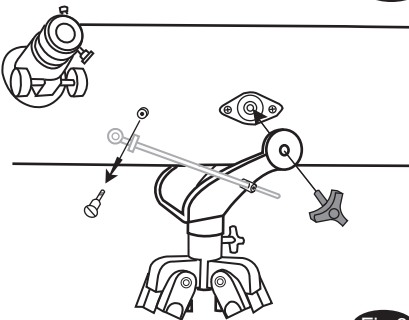
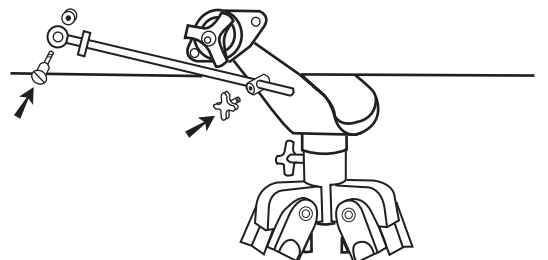
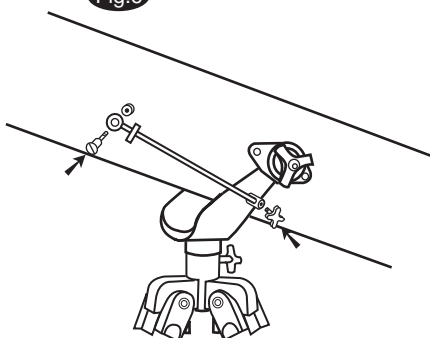

Fig.6

Fig.6



FINDERSCOPE ASSEMBLY

AZ1 (reflector)

AZ2 (refractor)

Fig.7

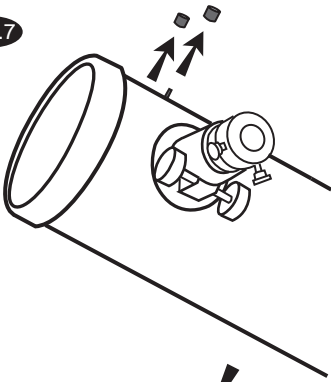

Fig.8

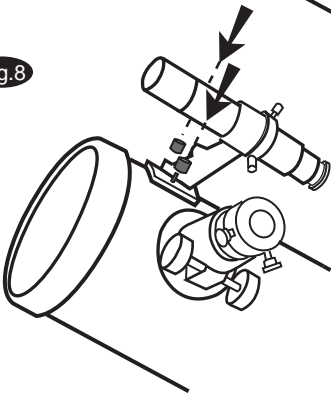

Fig.7

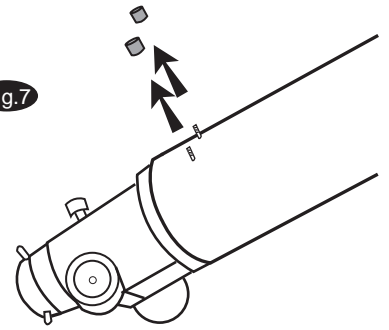
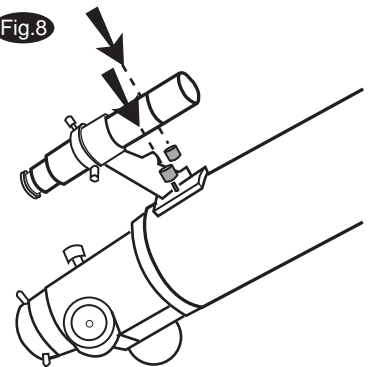

Fig.8



ATTACHING THE FINDERSCOPE (Fig. 7, 8)

- 1) Locate finderscope optical assembly.
- 2) Remove the two knurled thumbscrews near the end of the telescope main tube.
- 3) Position the finderscope bracket over the screws in the telescope main body.
- 4) Secure the finderscope bracket with the two knurled thumbscrews.

EYEPIECE ASSEMBLY

AZ1 (reflector)

AZ2 (refractor)

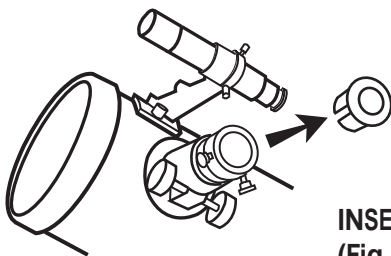
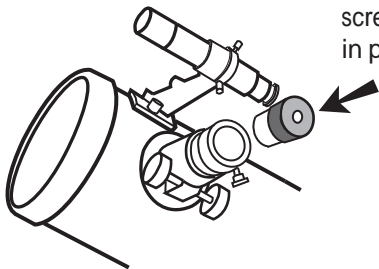

Fig.9



INSERTING EYEPIECE (Fig. 9)

- 1) Unscrew the thumbscrews on the end of the focus tube to remove the black plastic end-cap.
- 2) Insert the desired eyepiece and re-tighten thumbscrews to hold eyepieces in place.

INSERTING EYEPIECE (Fig. 9)

- 1) Unscrew the thumbscrews on the end of the focus tube to remove the plastic endcap.
- 2) Insert diagonal and re-tighten thumbscrews to hold diagonal in place.
- 3) Loosen the thumbscrews on the diagonal.
- 4) Insert the desired eyepiece into diagonal and secure by re-tightening thumbscrews.

Fig.9

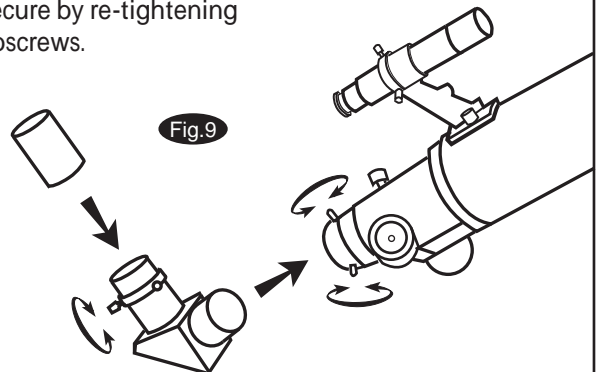

TRIPOD SET UP

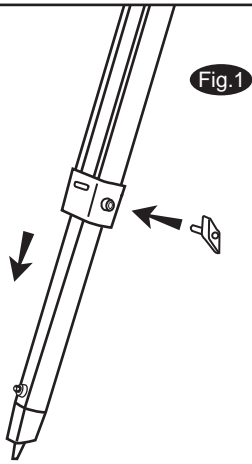

Fig.1

ADJUSTING TRIPOD LEGS (Fig.1)

- 1) Slowly loosen the height adjustment clamp and gently pull out the lower section of each tripod leg. Tighten the clamps to hold the legs in place.
- 2) Spread the tripod legs apart to stand the tripod upright.
- 3) Adjust the height of each tripod leg until the tripod head is properly leveled. Note that the tripod legs may not be at same length when the equatorial mount is level.

ATTACHING THE ACCESSORY TRAY (Fig. 2)

- 1) Place the accessory tray on top of the bracket, and secure with the locking knob from underneath.

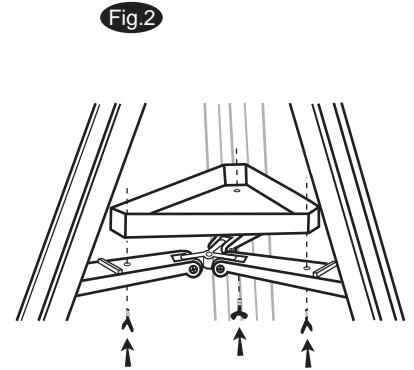

Fig.2

TELESCOPE ASSEMBLY

Without multi-function plate

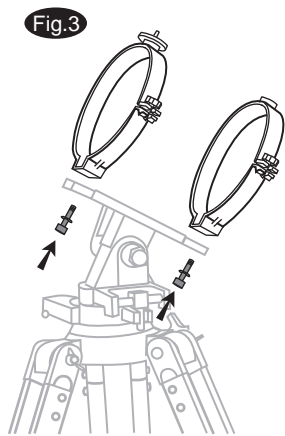

Fig.3

ATTACHING THE TUBE RINGS TO MOUNT(Fig.3)

- 1) Remove the tube rings from telescope by releasing their thumb nuts and opening their hinges.
- 2) Fasten the tube rings to the mount using the wrench provided.

ATTACHING THE TELESCOPE MAIN TUBE TO TUBE RINGS (Fig.4)

- 1) Find the center of balance of the telescope tube. Place this in between the two tube rings. Close the hinges around the telescope and fasten securely by tightening the thumb nuts. Do not over-tighten the thumb nuts.

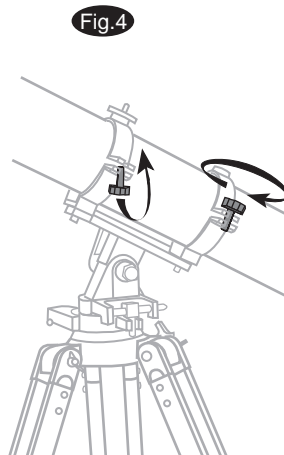

Fig.4

With multi-function plate

ATTACHING THE TUBE RINGS TO MOUNT(Fig.3)

- 1) Remove the tube rings-multifunction plate assembly from telescope by releasing their thumbnuts and opening their hinges.
- 2) Using one of the three threaded holes in the multi-function plate ring-plate assembly to the mounting platform. Turn the knurled black wheel directly underneath the mounting platform on the alt-az mount while holding the tube rings in place to secure the telescope in place.

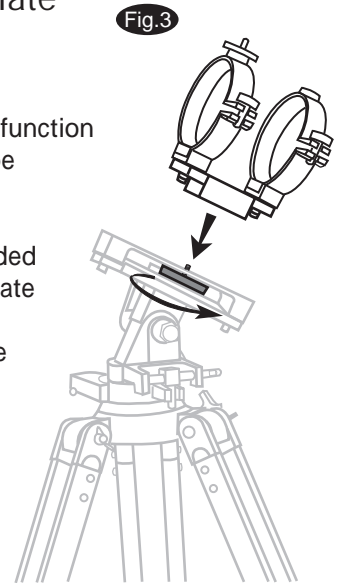

Fig.3

ATTACHING THE TELESCOPE MAIN TUBE TO TUBE RINGS (Fig.4)

- 1) Remove the telescope tube from the paper covering.
- 2) Place telescope tube in between the two tube rings. Close the hinges around the telescope and fasten securely by tightening the thumb nuts without over-tightening.

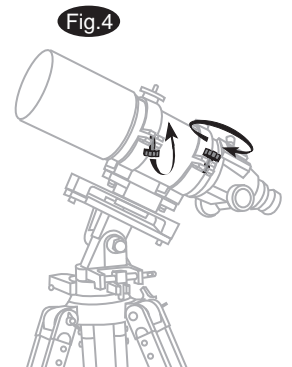

Fig.4

TELESCOPE ASSEMBLY

INSTALLING CONTROL CABLES (Fig.5)

- 1) Slide the sleeve end of the cable over the nipple on the end of the worm gear. Secure the cable by tightening the set screw against the flat surface on the nipple.

Fig.5

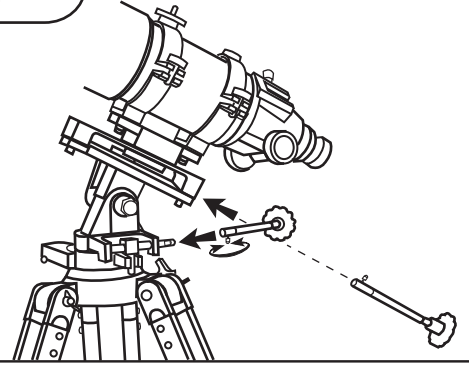

FINDERSCOPE/RED DOT FINDER ASSEMBLY

Small finderscope

ATTACHING THE FINDER-SCOPE (Fig.6)

- 1) Locate finderscope optical assembly.
- 2) Remove the two knurled thumbscrews near the end of the telescope main body.
- 3) Position the finderscope bracket over the screws in the telescope main body.
- 4) Secure the finderscope bracket with the two knurled thumbscrews.

Fig.6

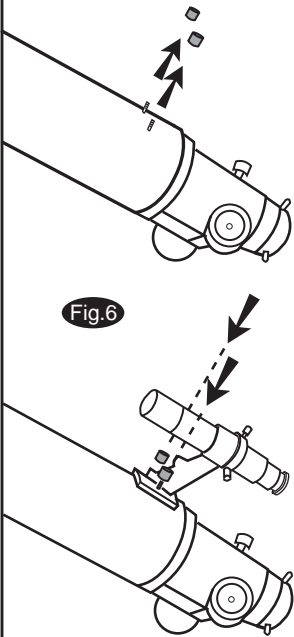

Large finderscope / Red dot finder

ATTACHING THE FINDERSCOPE BRACKET / RED DOT FINDER (Fig.6)

- 1) (For finderscope only): Locate the finderscope bracket and carefully remove the rubber-o-ring from it. Position the o-ring into groove on the finderscope tube.
- 2) Slide finderscope assembly/ red dot finder into the rectangular slot and tighten the thumbscrew to hold the bracket in place.

Fig.6

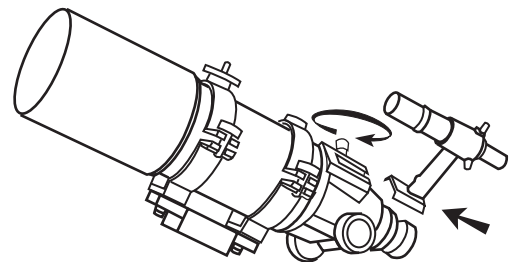

EYEPIECE ASSEMBLY

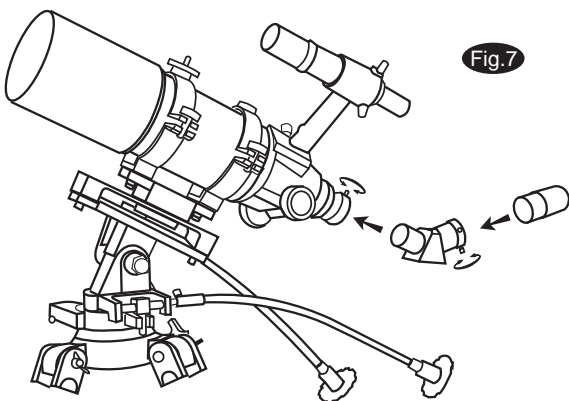

Fig.7

INSERTING DIAGONAL AND EYEPIECE (Fig.7)

- 1) Loosen the thumbscrew on the end of the focus tube.
- 2) Insert a diagonal into the focus tube and re-tighten the thumbscrew to hold the diagonal in place.
- 3) Loosen the thumbscrews on the diagonal.
- 4) Insert the desired eyepiece into the diagonal and secure by re-tightening the thumbscrews.

OPERATING YOUR TELESCOPE

Aligning the finderscope

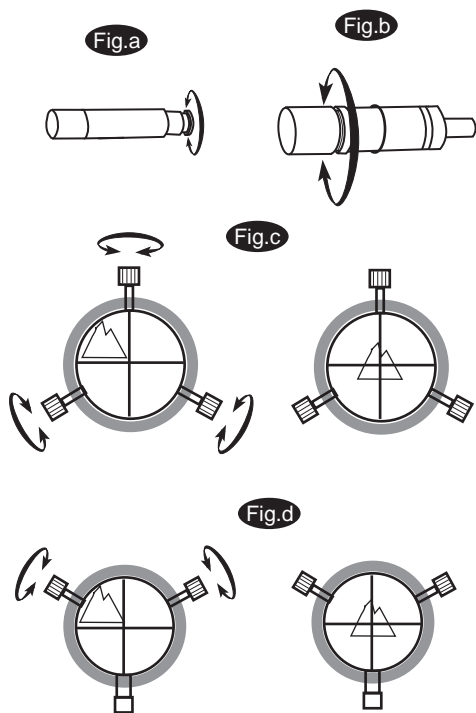

These fixed magnification scopes mounted on the optical tube are very useful accessories. When they are correctly aligned with the telescope, objects can be quickly located and brought to the centre of the field. Alignment is best done outdoors in day light when it's easier to locate objects. If it is necessary to refocus your finderscope, sight on an object that is at least 500 yards (metres) away. For 5x24 and 6x24 finderscope: twist the end of the finderscope until focus is reached (Fig.a). For 6x30 finderscope: loosen the locking ring by unscrewing it back towards the bracket. The front lens holder can now be turned in and out to focus. When focus is reached, lock it in position with the locking ring (Fig.b).

1. Choose a distant object that is at least 500 yards away and point the main telescope at the object. Adjust the telescope so that the object is in the centre of the view in your eyepiece.
2. Check the finderscope to see if the object centred in the main telescope view is centred on the crosshairs.
3. For the 5x24 finderscope, use the three alignment screws to centre the finderscope crosshairs on the object (Fig.c). For the 6x30 finderscope with spring loading, adjust only the two small screws (Fig.d).

Using the Red Dot Finder

The Red Dot Finder is a zero magnification pointing tool that uses a coated glass window to superimpose the image of a small red dot onto the night sky. The Red Dot Finder is equipped with a variable brightness control, azimuth adjustment control, and altitude adjustment control (Fig.e). The Red Dot Finder is powered by a 3-volt lithium battery located underneath at the front. To use the Finder, simply look through the sight tube and move your telescope until the red dot merges with the object. Make sure to keep both eyes open when sighting.

Aligning the Red Dot Finder

Like all finderscopes, the Red Dot Finder must be properly aligned with the main telescope before use. This is a simple process using the azimuth and altitude control knobs.

1. Open the battery cover by pulling it down (you can gently pry at the 2 small slots) and remove the plastic shipping cover over the battery (Fig.f). Turn on the Red Dot Finder by rotating the variable brightness control clockwise until you hear a "click". Continue rotating the control knob to increase the brightness level. Insert a low power eyepiece into the telescope's focuser. Locate a bright object and position the telescope so that the object is in the centre of the field of view. With both eyes open, look through the sight tube at the object. If the red dot overlaps the object, your Red Dot Finder is perfectly aligned. If not, turn its azimuth and altitude adjustment controls until the red dot is merged with the object.
- 2.
- 3.
- 4.

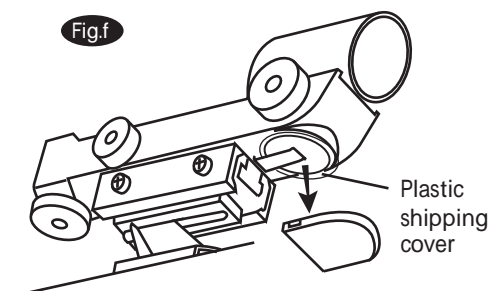
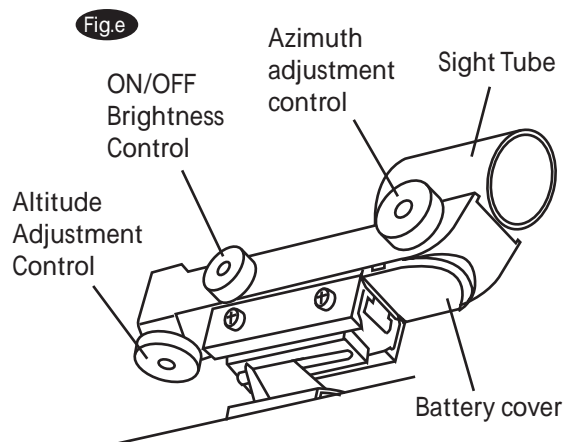

Operating the AZ1/AZ2 mount

This telescope has an altitude(up-down)-azimuth(left-right) mount to control telescope movements. Loosen the azimuth lock knob to make left-right direction movements then tighten to lock. Loosen the altitude lock knob to make course up-down changes. Altitude fine adjustments can be made by rotating the knurled wheel on the altitude fine adjustment rod after tightening the altitude lock knob. (AZ1: Fig.g, AZ2: Fig.h)

Operating the AZ3 mount

This mount has controls for movement in altitude (up-down) and azimuth (left-right). Coarse azimuth movement is controlled by a locking knob located near the tripod head for left-right rotation. Loosen the knob to make large direction changes then lock it for fine adjustments. Coarse Altitude movement is controlled by a friction bolt. Use the micro-adjustment control cables to make small altitude and azimuth movements such as centring objects in view. (Fig.i).

Using the Barlow lens

A Barlow is a negative lens which increases the magnifying power of an eyepiece, while reducing the field of view. It expands the cone of the focussed light before it reaches the focal point, so that the telescope's focal length appears longer to the eyepiece.

The Barlow is inserted between the focuser and the eyepiece in a reflector, and usually between the diagonal and the eyepiece in a refractor or a catadioptric (Fig.j). With some telescopes, it can also be inserted between the focuser and the diagonal, and in this position it gives even greater magnification. For example, a 2X Barlow when inserted after the diagonal can become 3X when placed in front of the diagonal.

In addition to increasing magnification, the benefits of using a Barlow lens include improved eye relief, and reduced spherical aberration in the eyepiece. For this reason, a Barlow plus a lens often outperform a single lens producing the same magnification. However, its greatest value may be that a Barlow can potentially double the number of eyepiece in your collection.

Focusing

Slowly turn the focus knobs (Fig.k), one way or the other, until the image in the eyepiece is sharp. The image usually has to be refocused over time, due to small variations caused by temperature changes, exures, etc. This often happens with short focal ratio telescopes, particularly when they haven't yet reached outside temperature. Refocusing is almost always necessary when you change an eyepiece or add or remove a Barlow lens.

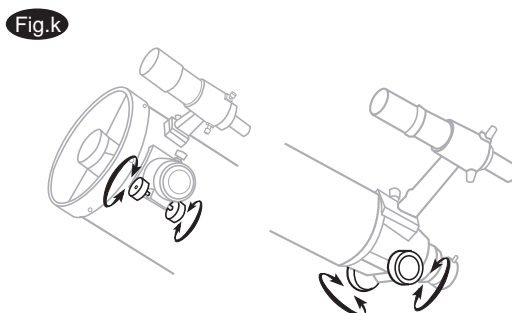
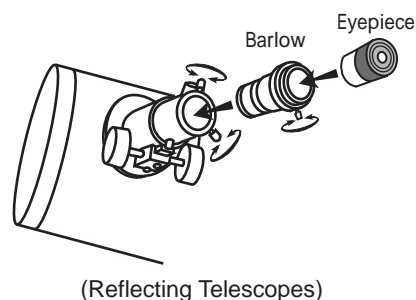
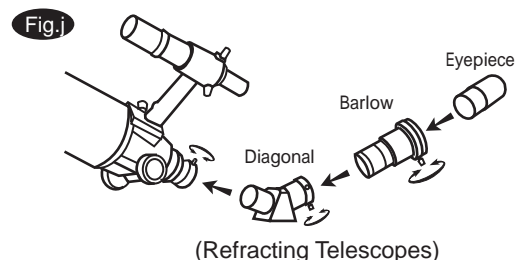
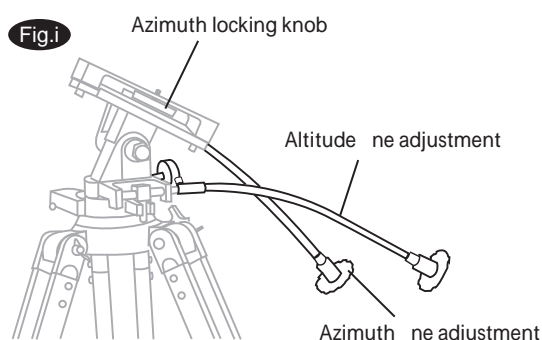
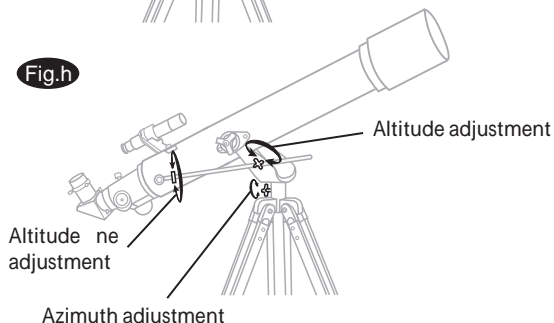
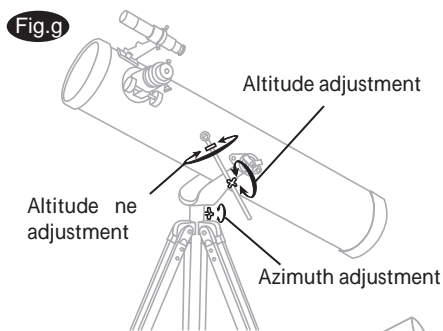

Using the Camera Adapter Tube

When you connect a camera directly to your telescope for "prime focus" photography, you sometimes require an adapter so that the camera can be focussed. Some reflectors need more length than the focuser can travel, in order to focus the camera, and some refractors are designed to be used with diagonals, so when used with only a camera, their focal length has to be extended. This is particularly true when photographing near objects. Your camera with its telescope "lens" may focus on a distant object such as a star, but will require the 2.5" camera adapter tube to focus on a near object such as a bird.

The camera adapter tube is easily installed by screwing it onto the T-threads of the eyepiece holder, then screwing the specific T-adapter ring for your camera (optional) onto the T-threads on the other end of the camera adapter tube (Fig.l). This makes the telescope into a "lens" which you then attach to your camera as you would any other lens.

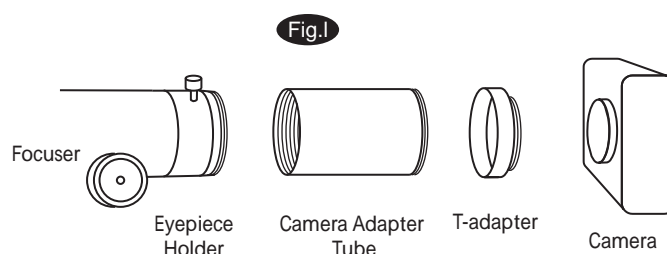

Pointing your telescope

Pointing an altitude-azimuth (alt-az) mounted telescope is relatively easy. With the mount level, you can swivel the telescope around on a plane parallel to your horizon and then tilt it up and down from there (Fig.c). You can think of it as turning your telescope in azimuth until it is facing the horizon below a celestial object and then tilting it up to the object's altitude. However, the Earth rotates and therefore the stars are constantly moving, so to track with this mount you need to constantly nudge the optical tube in both azimuth and altitude to keep the object in the field.

In reference material for your local position, the altitude will be listed as \pm degrees (minutes, seconds) above or below your horizon. Azimuth may be listed by the cardinal compass points such as N, SW, ENE, etc., but it is usually listed in 360 degree (minutes, seconds) steps clockwise from North (0°), with East, South and West being 90° , 180° and 270° , respectively (Fig.m).

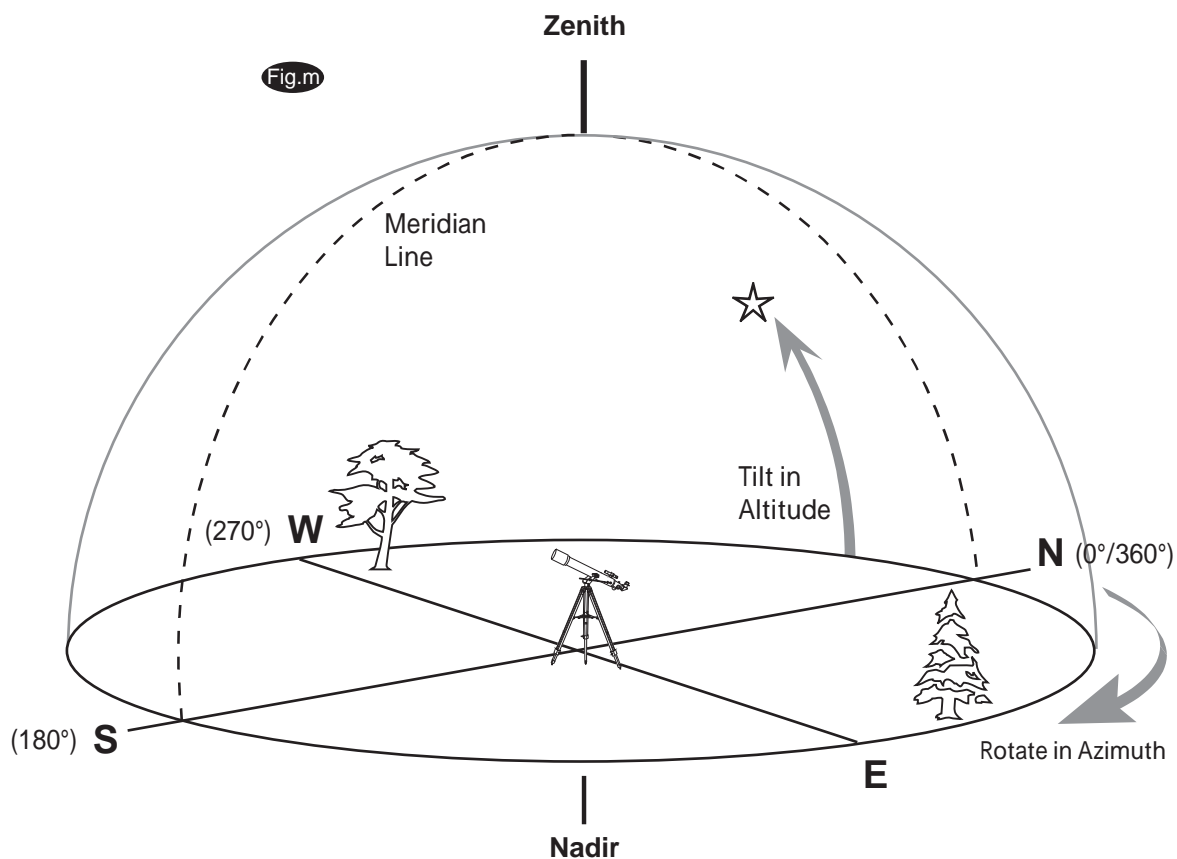

Calculating the magnification (Power)

The magnification produced by a telescope is determined by the focal length of the eyepiece that is used with it. To determine a magnification for your telescope, divide its focal length by the focal length of the eyepieces you are going to use. For example, a 10mm focal length eyepiece will give 80X magnification with an 800mm focal length telescope.

$$\text{magnification} = \frac{\text{Focal length of the telescope}}{\text{Focal length of the eyepiece}} = \frac{800\text{mm}}{10\text{mm}} = 80\text{X}$$

When you are looking at astronomical objects, you are looking through a column of air that reaches to the edge of space and that column seldom stays still. Similarly, when viewing over land you are often looking through heat waves radiating from the ground, house, buildings, etc. Your telescope may be able to give very high magnification but what you end up magnifying is all the turbulence between the telescope and the subject. A good rule of thumb is that the usable magnification of a telescope is about 2X per mm of aperture under good conditions.

Calculating the field of view

The size of the view that you see through your telescope is called the true (or actual) field of view and it is determined by the design of the eyepiece. Every eyepiece has a value, called the apparent field of view, which is supplied by the manufacturer. Field of view is usually measured in degrees and/or arc-minutes (there are 60 arc-minutes in a degree). The true field of view produced by your telescope is calculated by dividing the eyepiece's apparent field of view by the magnification that you previously calculated for the combination. Using the figures in the previous magnification example, if your 10mm eyepiece has an apparent field of view of 52 degrees, then the true field of view is 0.65 degrees or 39 arc-minutes.

$$\text{True Field of View} = \frac{\text{Apparent Field of View}}{\text{Magnification}} = \frac{52^\circ}{80\text{X}} = 0.65^\circ$$

To put this in perspective, the moon is about 0.5° or 30 arc-minutes in diameter, so this combination would be fine for viewing the whole moon with a little room to spare. Remember, too much magnification and too small a field of view can make it very hard to find things. It is usually best to start at a lower magnification with its wider field and then increase the magnification when you have found what you are looking for. First find the moon then look at the shadows in the craters!

Calculating the exit pupil

The Exit Pupil is the diameter (in mm) of the narrowest point of the cone of light leaving your telescope. Knowing this value for a telescope-eyepiece combination tells you whether your eye is receiving all of the light that your primary lens or mirror is providing. The average person has a fully dilated pupil diameter of about 7mm. This value varies a bit from person to person, is less until your eyes become fully dark adapted and decreases as you get older. To determine an exit pupil, you divide the diameter of the primary of your telescope (in mm) by the magnification.

$$\text{Exit Pupil} = \frac{\text{Diameter of Primary mirror in mm}}{\text{Magnification}}$$

For example, a 200mm f/5 telescope with a 40mm eyepiece produces a magnification of 25x and an exit pupil of 8mm. This combination can probably be used by a young person but would not be of much value to a senior citizen. The same telescope used with a 32mm eyepiece gives a magnification of about 31x and an exit pupil of 6.4mm which should be fine for most dark adapted eyes. In contrast, a 200mm f/10 telescope with the 40mm eyepiece gives a magnification of 50x and an exit pupil of 4mm, which is fine for everyone.

OBSERVING THE SKY

Sky conditions

Sky conditions are usually defined by two atmospheric characteristics, seeing, or the steadiness of the air, and transparency, light scattering due to the amount of water vapour and particulate material in the air. When you observe the Moon and the planets, and they appear as though water is running over them, you probably have bad "seeing" because you are observing through turbulent air. In conditions of good "seeing", the stars appear steady, without twinkling, when you look at them with unassisted eyes (without a telescope). Ideal "transparency" is when the sky is inky black and the air is unpolluted.

Selecting an observing site

Travel to the best site that is reasonably accessible. It should be away from city lights, and upwind from any source of air pollution. Always choose as high an elevation as possible; this will get you above some of the lights and pollution and will ensure that you aren't in any ground fog. Sometimes low fog banks help to block light pollution if you get above them. Try to have a dark, unobstructed view of the horizon, especially the southern horizon if you are in the Northern Hemisphere and vice versa. However, remember that the darkest sky is usually at the "Zenith", directly above your head. It is the shortest path through the atmosphere. Do not try to observe any object when the light path passes near any protrusion on the ground. Even extremely light winds can cause major air turbulence as they flow over the top of a building or wall. If you try to observe on any structure, or even a sidewalk, movements you make may cause the telescope to vibrate. Pavement and concrete can also radiate stored heat which will affect observing.

Observing through a window is not recommended because the window glass will distort images considerably. And an open window can be even worse, because warmer indoor air will escape out the window, causing turbulence which also affects images. Astronomy is an outdoor activity.

Choosing the best time to observe

The best conditions will have still air, and obviously, a clear view of the sky. It is not necessary that the sky be cloud-free. Often broken cloud conditions provide excellent seeing. Do not view immediately after sunset. After the sun goes down, the Earth is still cooling, causing air turbulence. As the night goes on, not only will seeing improve, but air pollution and ground lights will often diminish. Some of the best observing time is often in the early morning hours. Objects are best observed as they cross the meridian, which is an imaginary line that runs through the Zenith, due North-South. This is the point at which objects reach their highest points in the sky. Observing at this time reduces bad atmospheric effects. When observing near the horizon, you look through lots of atmosphere, complete with turbulence, dust particles and increased light pollution.

Cooling the telescope

Telescopes require at least 10 to 30 minutes to cool down to outside air temperature. This may take longer if there is a big difference between the temperature of the telescope and the outside air. This minimizes heat wave distortion inside telescope tube (tube currents). Allow a longer cooling time for larger optics. If you are using an equatorial mount, use this time for polar alignment.

Adapting your eyes

Do not expose your eyes to anything except red light for 30 minutes prior to observing. This allows your pupils to expand to their maximum diameter and build up the levels of optical pigments, which are rapidly lost if exposed to bright light. It is important to observe with both eyes open. This avoids fatigue at the eyepiece. If you find this too distracting, cover the non-used eye with your hand or an eye patch. Use averted vision on faint objects: The center of your eye is the least sensitive to low light levels. When viewing a faint object, don't look directly at it. Instead, look slightly to the side, and the object will appear brighter.

PROPER CARE FOR YOUR TELESCOPE

Collimating a Newtonian

Collimation is the process of aligning the mirrors of your telescope so that they work in concert with each other to deliver properly focused light to your eyepiece. By observing out-of-focus star images, you can test whether your telescope's optics are aligned. Place a star in the centre of the field of view and move the focuser so that the image is slightly out of focus. If the seeing conditions are good, you will see a central circle of light (the Airy disc) surrounded by a number of diffraction rings. If the rings are symmetrical about the Airy disc, the telescope's optics are correctly collimated (Fig.n).

If you do not have a collimating tool, we suggest that you make a "collimating cap" out of a plastic 35mm film canister (black with gray lid). Drill or punch a small pinhole in the exact center of the lid and cut off the bottom of the canister. This device will keep your eye centered of the focuser tube. Insert the collimating cap into the focuser in place of a regular eyepiece.

Collimation is a painless process and works like this:

Pull off the lens cap which covers the front of the telescope and look down the optical tube. At the bottom you will see the primary mirror held in place by three clips 120° apart, and at the top the small oval secondary mirror held in a support and tilted 45° toward the focuser outside the tube wall (Fig.o).

The secondary mirror is aligned by adjusting the three smaller screws surrounding the central bolt. The primary mirror is adjusted by the three adjusting screws at the back of your scope. The three locking screws beside them serve to hold the mirror in place after collimation. (Fig.p)

Aligning the Secondary Mirror

Point the telescope at a lit wall and insert the collimating cap into the focuser in place of a regular eyepiece. Look into the focuser through your collimating cap. You may have to twist the focus knob a few turns until the reflected image of the focuser is out of your view. Note: keep your eye against the back of the focus tube if collimating without a collimating cap. Ignore the reflected image of the collimating cap or your eye for now, instead look for the three clips holding the primary mirror in place. If you can't see them (Fig.q), it means that you will have to adjust the three bolts on the top of the secondary mirror holder, with possibly an Allen wrench or Phillip's screwdriver. You will have to alternately or loosen one and then compensate for the slack by tightening the other two. Stop when you see all three mirror clips (Fig.r). Make sure that all three small alignment screws are tightened to secure the secondary mirror in place.

Fig.n

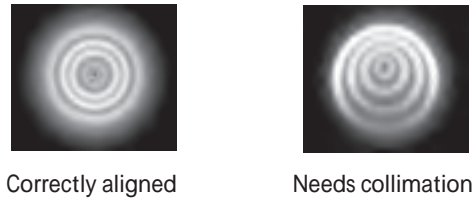

Fig.o

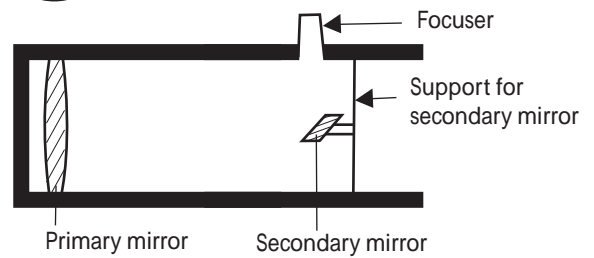

Fig.p

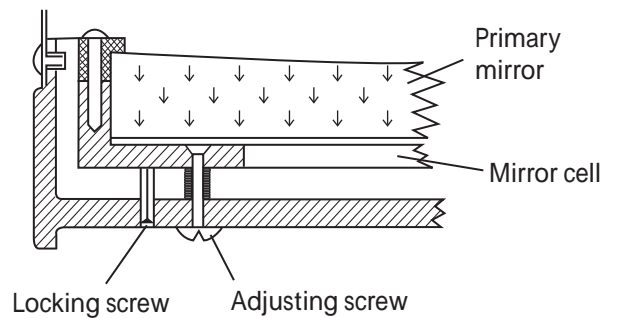

Fig.q

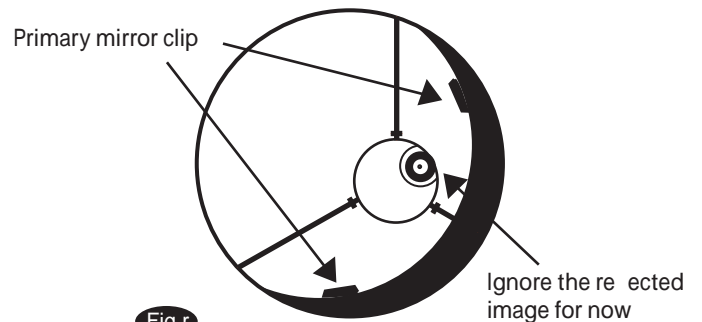
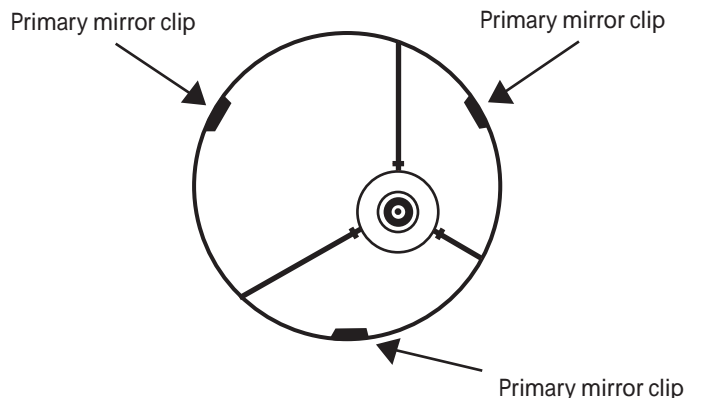

Fig.r



Aligning the Primary Mirror

Find the three locking screws at the back of your telescope and loosen them by a few turns.

Adjusting screw Locking screw

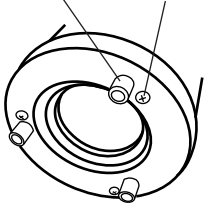

If you see 3 large nuts protruding from the back of your telescope and 3 small Phillip's-head screws besides them, the Phillip's-head screws are the locking screws and the large nuts are the adjusting screws.

Locking screw Adjusting screw

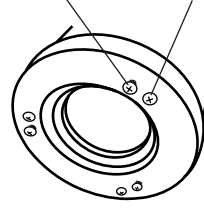

If you see 6 Phillip's-head screws but 3 protruding from the back of your telescope, the 3 protruding screws are locking screws and the ones next to them are adjusting screws.

hex bolt (Locking screw) Adjusting screw

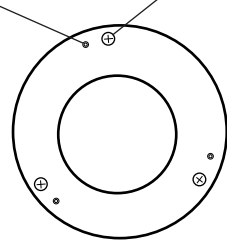

If you see 3 hex bolts and 3 Phillip's head screws, the hex bolts are the locking screws and the Phillip's-head screws are the adjusting screws. You will need an Allen wrench to adjust the locking screws.

Now run your hand around the front of your telescope keeping your eye to the focuser, you will see the re ected image of your hand. The idea here being to see which way the primary mirror is deflected, you do this by stopping at the point where the re ected image of the secondary mirror is closest to the primary mirrors' edge (Fig.s).

When you get to that point, stop and keep your hand there while looking at the back end of your telescope, is there a adjusting screw there? If there is you will want to loosen it (turn the screw to the left) to bring the mirror away from that point. If there isn't a adjusting screw there, then go across to the other side and tighten the adjusting screw on the other side. This will gradually bring the mirror into line until it looks like Fig.t. (It helps to have a friend to help for primary mirror collimation. Have your partner adjust the adjusting screws according to your directions while you look in the focuser.)

After dark go out and point your telescope at Polaris, the North Star. With an eyepiece in the focuser, take the image out of focus. You will see the same image only now, it will be illuminated by starlight. If necessary, repeat the collimating process only keep the star centered while tweaking the mirror.

Fig.s

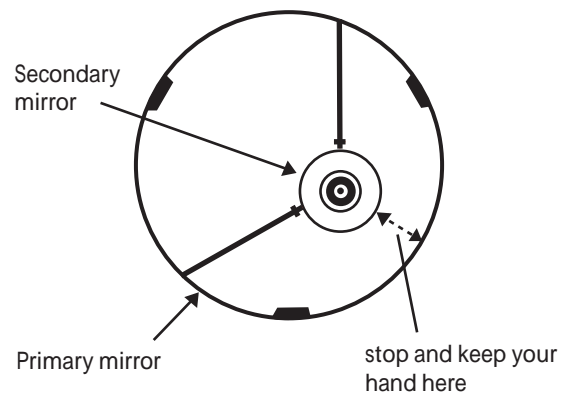
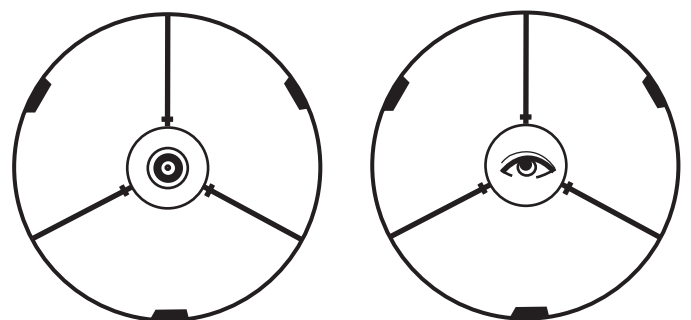

Fig.t



Both mirrors aligned with collimating cap in

Both mirrors aligned with eye looking in focuser

Cleaning your telescope

Replace the dust cap over end of telescope whenever not in use. This prevents dust from settling on mirror or lens surface. Do not clean mirror or lens unless you are familiar with optical surfaces. Clean nderscope and eyepieces with special lens paper only. Eyepieces should be handled with care, avoid touching optical surfaces.

CAUTION!



NEVER USE YOUR TELESCOPE TO LOOK DIRECTLY AT THE SUN. PERMANENT EYE DAMAGE WILL RESULT. USE A PROPER SOLAR FILTER FIRMLY MOUNTED ON THE FRONT OF THE TELESCOPE FOR VIEWING THE SUN. WHEN OBSERVING THE SUN, PLACE A DUST CAP OVER YOUR FINDERSCOPE OR REMOVE IT TO PROTECT YOU FROM ACCIDENTAL EXPOSURE. NEVER USE AN EYEPiece-TYPE SOLAR FILTER AND NEVER USE YOUR TELESCOPE TO PROJECT SUNLIGHT ONTO ANOTHER SURFACE, THE INTERNAL HEAT BUILD-UP WILL DAMAGE THE TELESCOPE OPTICAL ELEMENTS.